

This drawing/document is a COPYRIGHT and the property of ADAPTAflex LIMITED. It must not be copied (in whole or part) used for manufacture or otherwise disclosed without prior written consent of the company

THIRD ANGLE PROJECTION

IF IN DOUBT ASK

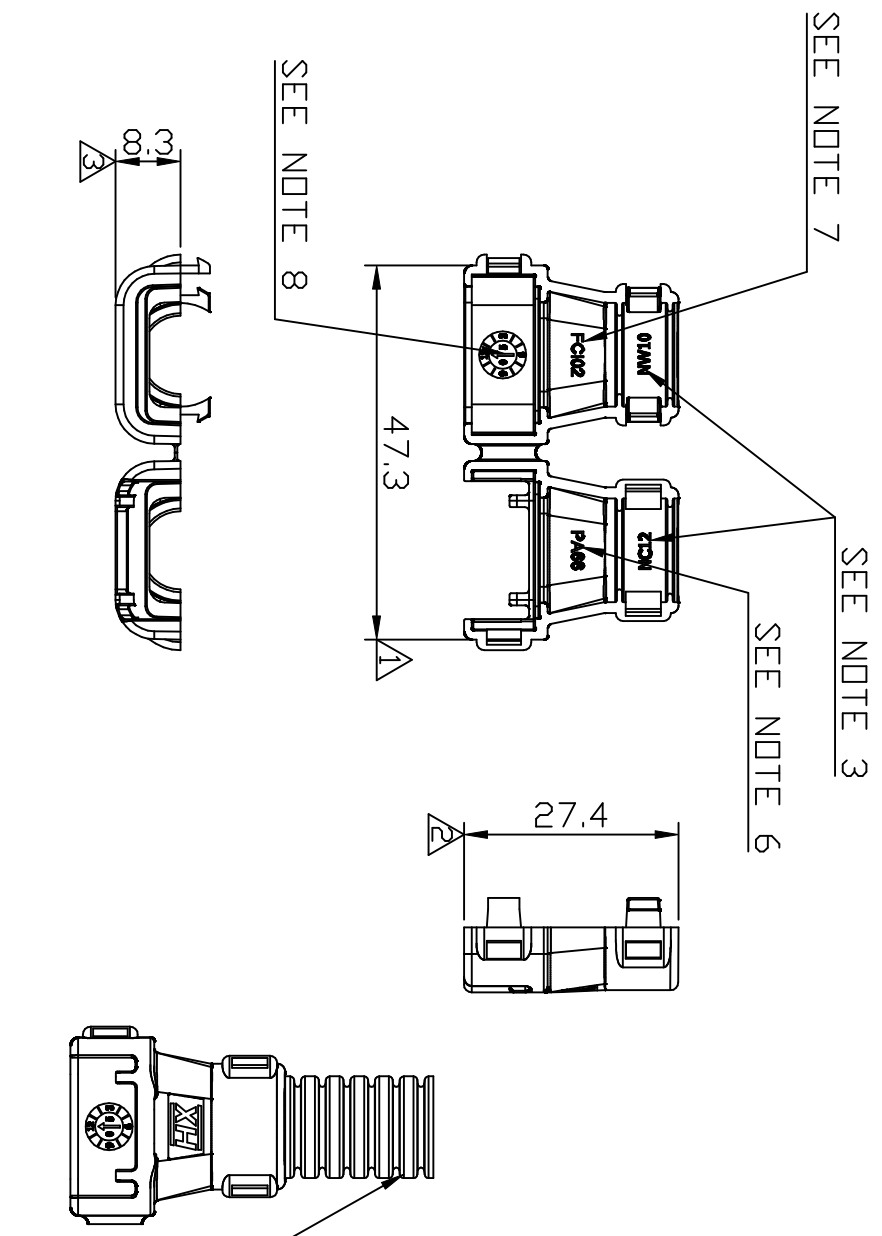

NOTES

- 1.FOR FULL COMPONENT DETAILS SEE DRAWINGS HELD BY DESIGN DEPARTMENT,
- 2.QUALITY CHECK DIMENSIONS INDICATED BY ∇ QUANTITY 4
- 3.CHECK INTERNAL INSERT IDENTIFICATION 2 PLACES
4. ASSEMBLE CONDUIT AS SHOWN AND CLOSE TO ENSURE CLIP INTEGRITY
- 5.TEST HINGE BY FLEXING 10 TIMES TO EXTENTS OF MOVEMENT (WITHOUT LATCHING CLIPS) WITH NO BREAKAGE OF HINGE.
- 6.CHECK MATERIAL REFERENCE - PA66
- 7.CHECK PART IDENTITY - FC102
- 8.CHECK DATE CLOCK, YEAR AND MONTH
- 9.FOR REGROUND LEVELS SEE : CD24
- 10.FOR CONDITIONING REQUIREMENTS SEE : CD25

MANUFACTURING DRAWING



BIRMINGHAM ENGLAND

TITLE

CI12-FC102

DRAWING NO. 4454 ISSUE 1

MATERIAL	NYLON 66 - BLACK
TUOL No.	AM169
WEIGHT	2.4g
GENERAL TOLERANCE	± 0.2
UNSPECIFIED RADII	0.1 TO 0.2
ALL DIMENSIONS	IN MM
DO NOT SCALE FROM DRAWING	
DRAWN BY	M. BUCK
DATE	11/07/05
APPROVED BY	

NO	MODIFICATIONS	DATE	INTLS

