

Conductive Polymer Aluminum Solid Electrolytic Capacitors

○ Page number

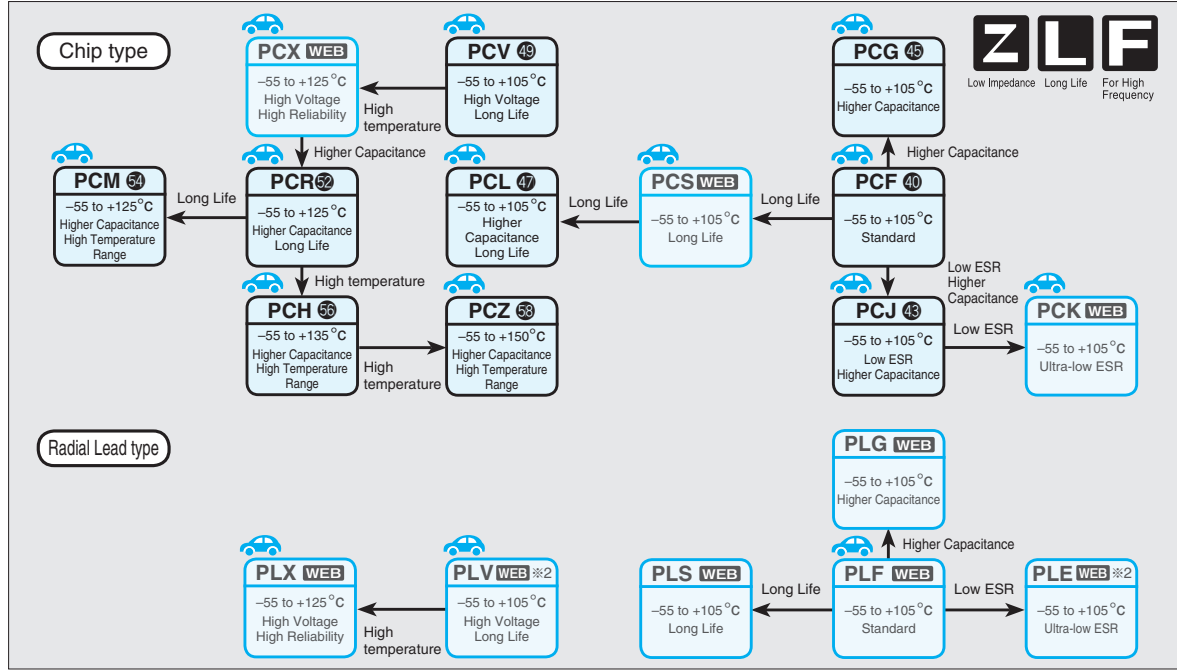

System Diagram for FPCAP

SMD type

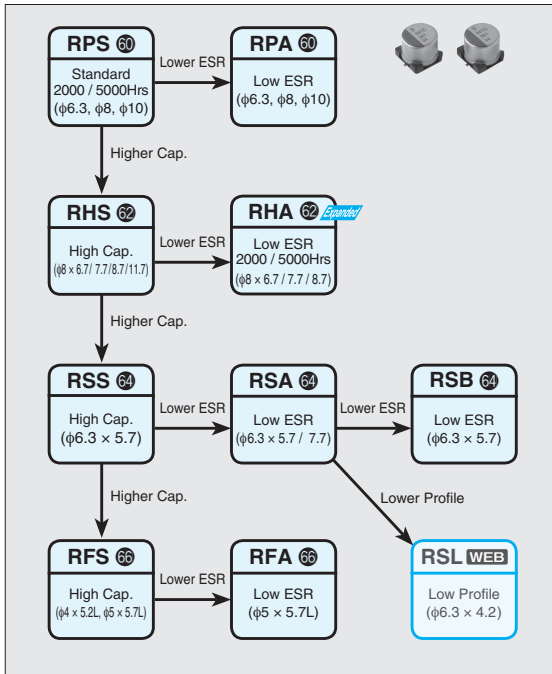

Radial Lead type

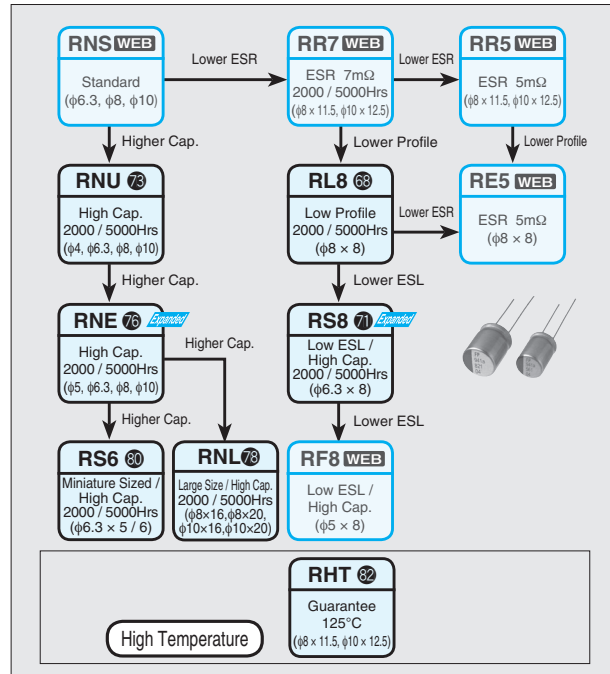

Conductive Polymer Hybrid Aluminum Electrolytic Capacitors

Chip type

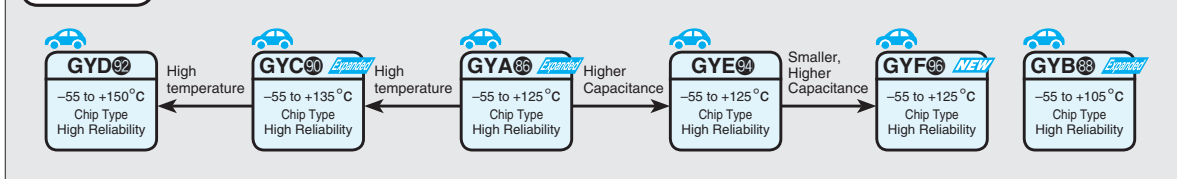

#2 Products which are scheduled to be discontinued, Not recommended for new designs.

AEC-Q200 compliant. Please contact us for details.

Please refer to our website for the details of the series described as "WEB".

Chip Aluminum Electrolytic Capacitors

○ Page number

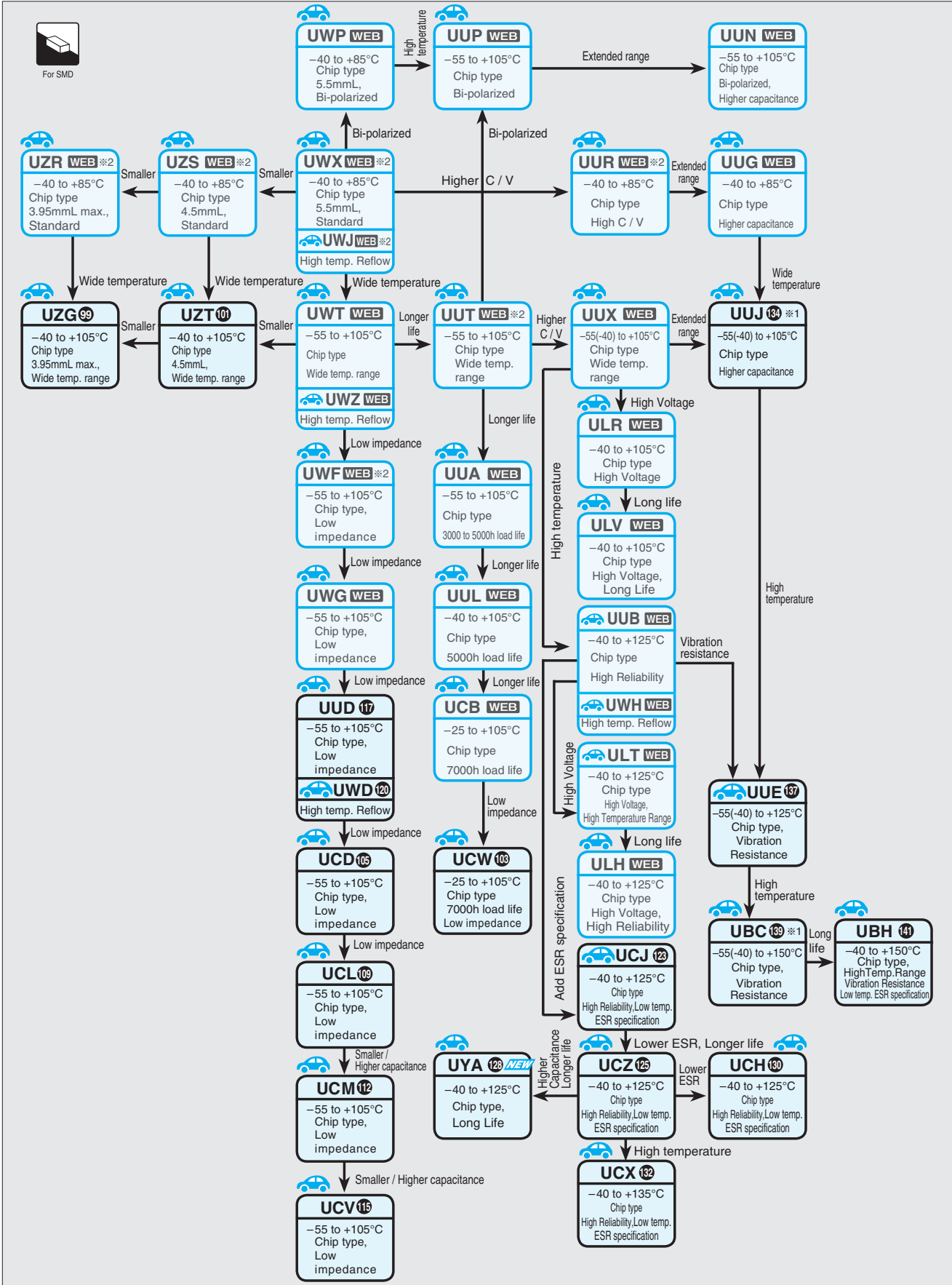

※1 May have values that are products which are scheduled to be discontinued. They are not recommended for new designs. Please refer to the series data pages for details.
 ※2 Products which are scheduled to be discontinued, Not recommended for new designs.

AEC-Q200 compliant. Please contact us for details.

Please refer to our website for the details of the series described as "WEB".

CAT.8100L

Large Can Aluminum Electrolytic Capacitors

○ Page number

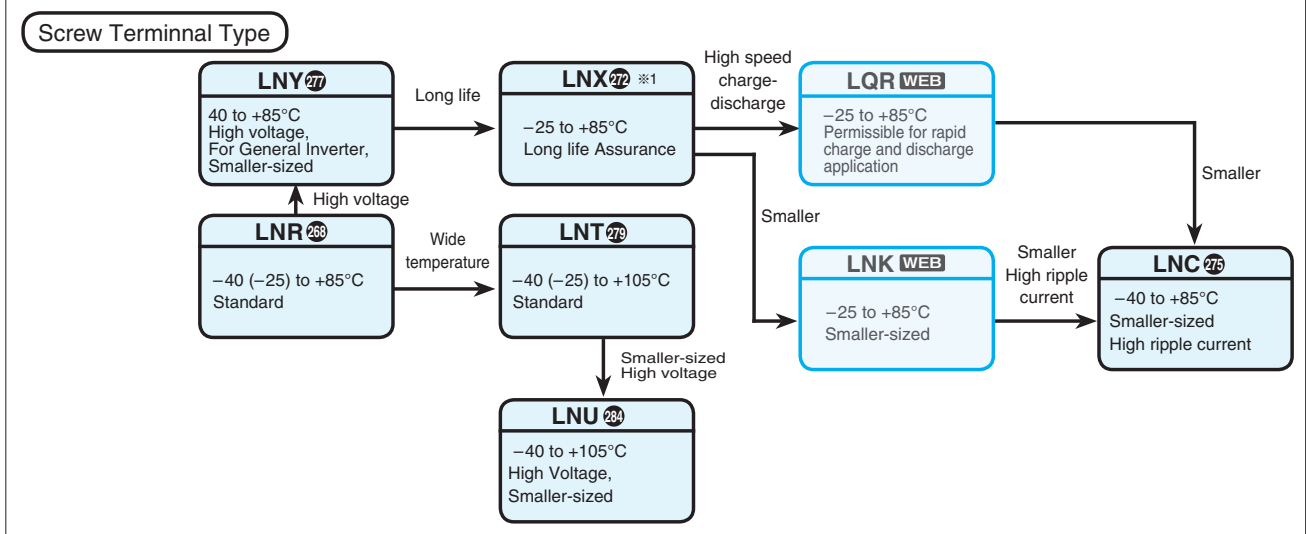
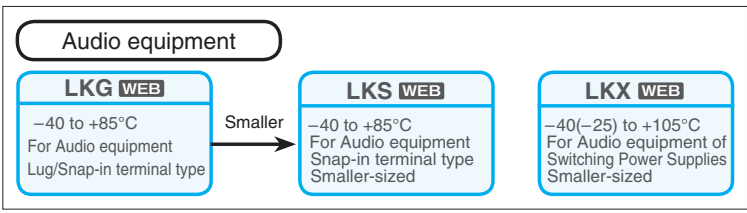
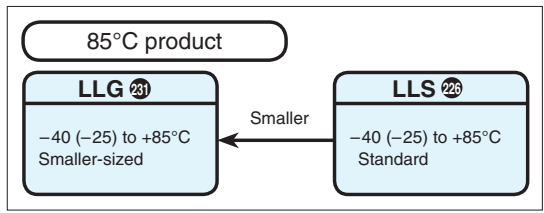
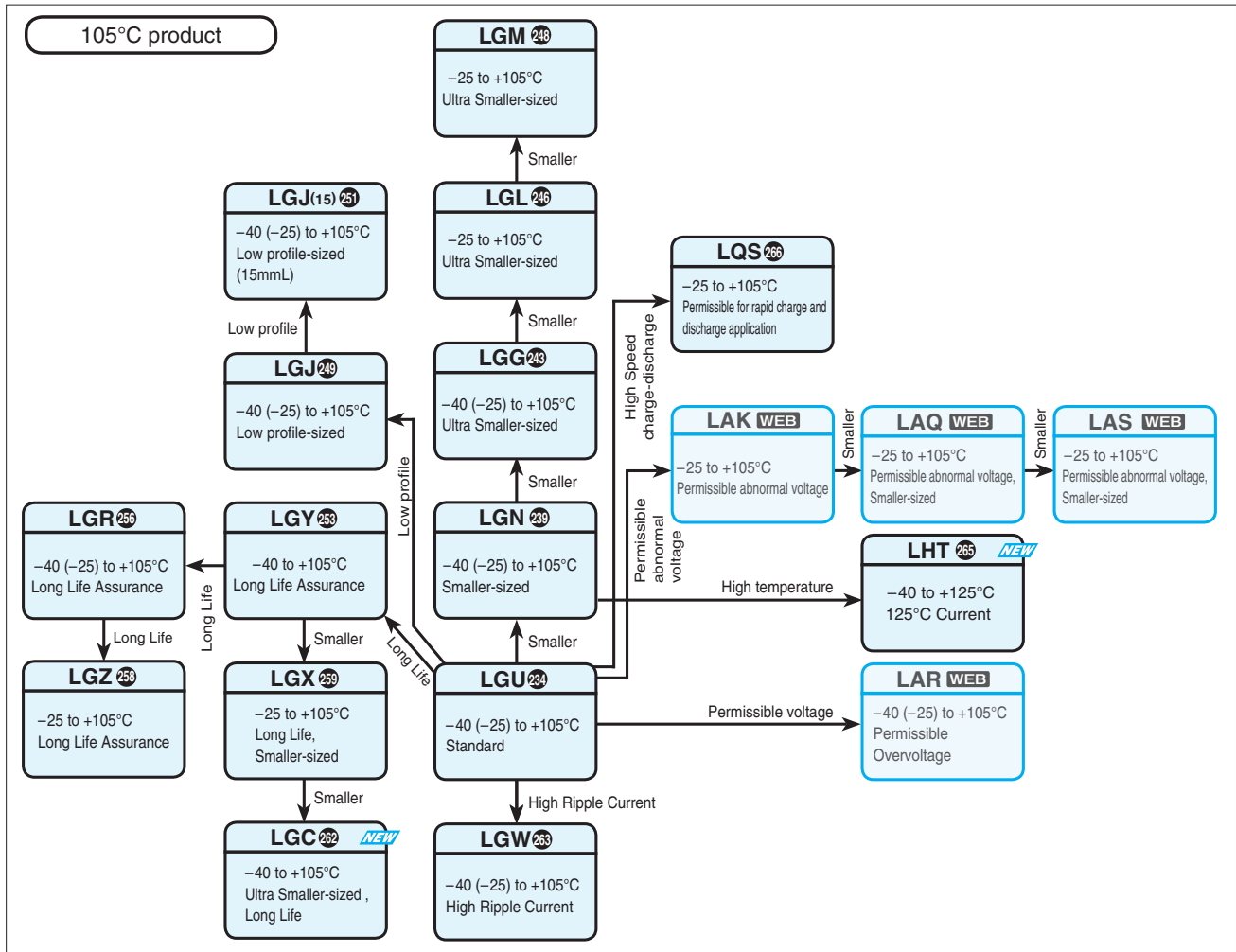

*1 May have values that are products which are scheduled to be discontinued. They are not recommended for new designs. Please refer to the series data pages for details.

Please refer to our website for the details of the series described as "WEB".